



nova VERTA
international s.p.a.



MAINTENANCE

MANUAL

NOVA VERTA INT.S.P.A.



INDEX

• TERMS AND DEFINITIONS	pag. 3
• GENERAL CAUTIONS	pag. 4
• REGULATIONS FOR SAFE USE AND MAINTENANCE	pag. 5
• PERIODIC MAINTENANCE OPERATIONS	pag. 8
• TROUBLESHOOTING GUIDE	pag. 10
• PREFILTERS	pag. 12
• PLENUM FILTERS	pag. 13
• UNDERGRATING FILTERS	pag. 18
• EXTRACTION FILTERS	pag. 20
• CENTRIFUGAL FANS	pag. 26
• WATER WASH EXHAUST UNIT	pag. 29
• PRESSURE INSIDE THE BOOTH	pag. 33
• DWYER MANOMETER INSTALLATION	pag. 35
• TRANSMISSION BELTS	pag. 38
• ELECTROVALVES AND PNEUMATIC PISTONS	pag. 41
• COUNTERWEIGHT INLET DAMPER	pag. 43
• SEAL	pag. 47
• BOOTH INTERIOR	pag. 46
• BURNER	pag. 48

TERMS AND DEFINITIONS

Definitions of some of the terms used in the manual are given below in order to facilitate the consultation and use of the manual.

BOOTH-OVEN	A closed, heat-ventilated environment where painting and drying of vehicles or vehicle parts is carried out. Equipped with vertical hot air flow from top to bottom
BASE	Base of booth-oven. It may be in stone or metalwork. Designed for holding the gratings that make up the floor of the booth-oven.
OVER-SPRAY	Paint product mix not deposited on the vehicle which is drawn out by the internal air flow
GRATING	Floor grating that allows the expulsion of air
FILTERS BENEATH GRATING	Dry filters inserted immediately under the gratings. Their function is to catch most of the paint product not deposited on the vehicle or part to be painted
FRONT DOOR	Access door to booth-oven
SERVICE DOOR	Door for operator (may be provided with anti-panic bars)
CONTROL PANEL	Panel with all the controls and programmes necessary for the booth-oven to function
TEMPERATURE THERMOREGULATOR	Device for setting and controlling temperature values
TEMPERATURE CONTROL DIGITAL DISPLAY	Temperature digital display
SPRAYING PHASE	Spraying/Painting operation
FLASH-OFF PHASE	Phase following the spraying/painting operation indispensable for complete exhalation of solvents from the applied paint
BAKING PHASE	Phase for drying applied paint
AIR RECIRCULATION	Recirculation of air from inside booth
PLENUM FOR AIR DISTRIBUTION	Chamber for expansion of air flow from generator set
PLENUM FILTERS	Filters for intake of air into booth
GENERATOR SET	Apparatus for the production of ventilated and heated air
HEAT EXCHANGER	Stainless steel apparatus for the exchange of heat between the combustion products and the air drawn in from outside and then input into booth
ANTIFIRE DAMPER	Device between the heat generator and the air distribution plenum which guarantees resistance to fire "REI 120". REI 120 is automatically activated when the safety temperature is exceeded. It interrupts the booth work cycle following an anomalous rise in the temperature of the intake air.
SMOKE STACK	Expulsion vent for combustion products
INTAKE DUCT	Metal connecting duct between generator set and air distribution plenum
AIR RECYCLE DUCT	Lower metal connecting duct between base and generator set
AIR DRY EXPULSION SET	Apparatus for the dry expulsion and blasting of powders
AIR DRY EXPULSION SET WITH ACTIVATED CARBONS	Apparatus for the dry expulsion and blasting of powders with activated carbon cartridges
WATER EXPULSION SET	Apparatus for the expulsion and blasting of powders with water
INTAKE FILTERS (PREFILTERS)	Powder blasting filters at the air intake
EXPULSION FILTERS	Powder blasting end filters
ACTIVATED CARBON CARTRIDGES	Solvent blasting end filters
REGULATION DAMPER	Device with fins for regulation (manual or power-assisted) of the internal pressure of the paint booth
EXPULSION DUCT	Square-section ducting for the expulsion of air from the extraction set into the atmosphere
INTAKE DUCTS	Metal square-section ducting for take up of air from atmosphere for input by the generator into the booth
BY-PASS	
PIECE TO BE PAINTED	Vehicle or vehicle part which is placed in booth ready for painting

GENERAL CAUTIONS

- PRESERVE THIS USE AND MAINTENANCE MANUAL CAREFULLY IN A SAFE PLACE. IT SHOULD ACCOMPANY THE EQUIPMENT IN EVERY PHASE OF ITS LIFE-CYCLE, INCLUDING IF IT SHOULD BE LATER SOLD ON, UNTIL ITS EVENTUAL DISMANTLING.
- READ THIS USE AND MAINTENANCE MANUAL CAREFULLY BEFORE USING THE EQUIPMENT
- USE THE EQUIPMENT ONLY FOR THE PURPOSES EXPRESSLY STATED IN THIS MANUAL. ANY OTHER USE IS INCORRECT AND POTENTIALLY DANGEROUS
- FOLLOW THE INSTRUCTIONS IN THIS MANUAL SCRUPULOUSLY IN REGARD TO ALL PHASES OF THE LIFE-CYCLE OF THE EQUIPMENT
- IN THE CASE OF ANY PROBLEM CONTACT ONLY SPECIALISED PERSONNEL AUTHORISED BY THE MANUFACTURER.
- THE MANUFACTURER RESERVES THE RIGHT TO MAKE ANY MODIFICATIONS TO THE MODEL AT ANY TIME WITHOUT ADVANCE NOTICE.
- THE MANUFACTURER DECLINES ANY RESPONSIBILITY FOR DAMAGE TO THE EQUIPMENT, OR TO PERSONS, ANIMALS OR THINGS DERIVING FROM FAILURE OR PARTIAL FAILURE TO OBSERVE THE REGULATIONS SET DOWN IN THIS MANUAL, OR FROM USE OF THE EQUIPMENT BY AN INADEQUATELY TRAINED OPERATOR, OR FROM UNAUTHORISED MODIFICATIONS, FROM DISASTERS OR NATURAL EVENTS WITH EXCEPTIONAL CHARACTERISTICS.
- THE MANUFACTURER DECLINES ANY RESPONSIBILITY FOR COMPONENTS DESIGNED AND REALISED BY THE CUSTOMER.
- THE EQUIPMENT REMAINS THE PROPERTY OF THE MANUFACTURER UNTIL IT HAS BEEN COMPLETELY PAID FOR.



WARNING!
READ THESE INSTRUCTIONS BEFORE
OPERATING THE EQUIPMENT



REGULATIONS FOR SAFE USE AND MAINTENANCE

This equipment should be used in accordance with the instructions in this manual. In particular, the following regulations and precautions must be scrupulously observed:

- Warning: The machine must be started up only from the control panel.
- Take care with live electrical components.
- Warning: the use of special accessories such as infrared heating systems may present a potential fire hazard.
- Do not work on moving parts.
- Do not remove the guards.
- Do not climb onto the roof of the booth.
- Do not smoke inside the booth or in the vicinity of the booth.
- Inside the booth, do not use naked flames, incandescent objects, tools that may produce sparks, or electrical apparatus that is not expressly designed for use in spray booths.
- Do not leave flammable substances, their empty containers, or any other material that may have been in contact with such substances (rags, paper etc.) in the booth or in front of the doors.
- Do not leave vehicles in the unventilated booth with their fuel filler caps open.
- Do not bring into the booth vehicles with gas fuel tanks or vehicles containing any explosive or flammable objects such as spray cans (deodorants, insecticides, paint, lacquer or hair sprays, etc.) lighters, bottles of alcohol or other chemicals, gun cartridges or ammunition, batteries etc.
- Do not spray more paint than the quantity indicated in the technical specifications for the equipment and on the equipment label.
- Do not spray paint (for example using auxiliary devices) if the equipment is not at the spraying phase.
- Do not spray when the booth doors are open.
- Do not omit the flashing phase, or carry out flashing in an unventilated booth.
- Do not keep or consume food or drink in the booth.
- Paint products that are brought into the booth must be immediately earthed.
- Protect respiratory passages (nose and mouth) with masks and filters.
- Wear protective clothing such as overalls, shirts and ear protectors
- Wear safety shoes.
- Use a respirator connected to fresh air when the operator is working inside a railway coach, lorry, bus or in the pit inside the booth.
- Ventilate the booth after maintenance and/or interruptions due to breakdown of the forced air ventilation system, and before bringing in a new vehicle for treatment.
- Follow the instructions in this manual.

IN CASE OF FIRE

In case of fire:

- Disconnect the electricity supply
- Disconnect the burner fuel supply, using the isolation valve outside the booth.
- Use ABC polyvalent dry powder fire-extinguishers which are suitable both for the materials used and where live electrical parts are present.

ACCIDENT PREVENTION SIGNS

THE USER SHOULD DISPLAY THE FOLLOWING SIGNS ON THE FRONT OF THE MACHINE



This warning sign should be on the control board, indicating hazard from live electrical parts.
This triangular warning sign is black on a yellow background.



CAUTION: READ THE INSTRUCTION MANUAL CAREFULLY BEFORE OPERATING THE EQUIPMENT

Circular prohibition signs, red on a white background, with images in black



DO NOT WORK ON MOVING PARTS



DO NOT REMOVE THE GUARDS



NO SMOKING

Display sign on both sides of every door in the booth



DO NOT USE NAKED FLAMES, INCANDESCENT OBJECTS OR EQUIPMENT THAT PRODUCES SPARKS







DO NOT LEAVE FLAMMABLE MATERIALS IN THE BOOTH OR IN FRONT OF THE DOORS



NO ACCESS TO ROOF OF BOOTH

Circular mandatory signs, white on a blue background

	<p style="text-align: center;">PROTECT RESPIRATORY PASSAGES</p>
	<p style="text-align: center;">WEAR PROTECTIVE CLOTHING</p>
	<p style="text-align: center;">WEAR SAFETY SHOES</p>
	<p style="text-align: center;">Appropriate emergency exit signs should be displayed in the booth</p>
	<p style="text-align: center;">The customer has responsibility for equipping the machinery with approved fire extinguishers, which should be placed near the booth and indicated with a rectangular sign with a white symbol on a red background, to be displayed near to each extinguisher:</p>

MAINTENANCE PROGRAMME

PERIODIC MAINTENANCE OPERATIONS

The following table indicates the maintenance operations that should be carried out by the user and the necessary frequency for each operation.

The frequency is expressed in operating hours as displayed on the hour counter located on the control panel.

PERIODIC MAINTENANCE OPERATIONS TO BE CARRIED OUT BY USER	
INTERVENTION	WORKING HOUR
	50 100 150 200 250 300 350 400 450 500 550 600 650 700 750 800 850 900 950 1000
Check overpressure of air in booth	Continuously, especially after every operation which may alter the flow of air
Check/supplement water in WW cleaning system (*)	Daily
Remove paint residue from WW cleaning system (*)	Daily
Check/Replace recirculation filter in WW cleaning system (*)	Daily
Change water and clean tank in WW cleaning system (*)	♦
Clean internal walls of booth and glass in light fixture panel	♦
Clean and air-blow generator pre-filters	♦
Check extraction filters	♦
Replace undergrating filters	♦
Replace extraction filters	♦
Replace generator pre-filters	♦
Grease pneumatic cylinder in recirculation door	♦
Grease door hinges, locks and handles	♦
Clean undergrating channels	♦
Grease fan bearings	♦
Check tension of fan belts	♦
Clean extraction fans	♦
Check/Replace door seals	♦
Clean extraction gratings	♦
Check proper functioning of recirculation door	♦
Clean burner stack	♦
Replace ceiling filters	♦
Check/clean air ducts	♦

(*) Only for wet wash cleaning systems WW and WW12CA

**PERIODIC MAINTENANCE OPERATIONS TO BE CARRIED OUT EXCLUSIVELY BY
TRAINED AND QUALIFIED PERSONNEL**

WORKING HOURS 1000

INTERVENTION	50	100	150	200	250	300	350	400	450	500	550	600	650	700	750	800	850	900	950	1000	
Check and service burner (**)										◆											
Check/clean heat exchanger (**)										◆											
Check earthing of machinery (**)										◆											

(**) This operation should be carried out at least once a year, independently of the number of operating hours.



**WARNING!
CARRY OUT MAINTENANCE ACCORDING TO
THE INSTRUCTIONS IN THIS MANUAL.
ONLY USE ORIGINAL SPARE PARTS**

MAINTENANCE PROGRAM

TROUBLESHOOTING GUIDE

The chart below indicates the most frequently encountered problems, their most likely causes and the steps necessary to solve the problem:

PROBLEM	CAUSE/SOLUTION
Reduced efficiency in speed of blast-cleaning of paint cloud	Check tension on fan transmission belts
	Irregular absorption by electric motors
	Check generator pre-filters, clean with jet of air or replace if necessary
	Check undergrating filters and extraction filters (air cleaning system) and replace if necessary
Imperfections present on sprayed products	Paint contaminated and/or not adequately filtered
	Check ceiling filters, clean and replace if necessary
	Product being treated is not sufficiently clean
	Inadequate isolation of the product parts being treated, which may release dust
	Operator is wearing dusty clothing
	Inadequate filtration and/or dehumidification of compressed air for spraying
	Check that spray gun is clean
One or more neon lights fail to light up	Replace starters if defective
	Replace reactors if burnt out
	Replace fluorescent tubes if defective
	Check correct contact of terminals
Failure to reach preset temperature for baking phase	Check burner ignition
	Check recirculation door of generator is functioning properly
	Check heat-regulating probe is functioning properly
	Check safety thermostat is functioning properly

SPARE PARTS

Only use ORIGINAL PARTS for the servicing and repair of the machinery.
When ordering spare parts, always indicate the machine registration number and type as indicated in the codification details in “Part 2” of this manual.

DISMANTLING

To dismantle the machinery:

- Always disconnect the power supply first
- Shut off the fuel supply to the burner
- Operate in accordance with the current accident prevention legislation: in particular, use scaffolding, lifting equipment, individual safety protection equipment and accessories that make it possible to operate in conditions of absolute safety.
- Remove paint as far as possible from the components on which it is deposited: these residues are pollutants and must be disposed of as “special waste”.
- Separate materials and components according to type
- Separate filtering materials and any activated carbon that is present as these are pollutants and must be disposed of as “special waste”.
- Recuperate any parts that may be re-used
- Contact companies or organisations that specialise in the disposal of special waste materials



**DO NOT DISPOSE OF THE MACHINE OR
ITS PARTS IN THE ENVIRONMENT**

MAINTENANCE PROGRAM

PRE-FILTERS

The pre-filters are inside the generator set, below the intake fan/s, and their function is to retain the dust and other impurities contained in the air before it is drawn into the booth. Clogging of the pre-filters causes a notable reduction in the amount of air in the booth with consequent deficiency of performance in blast-cleaning the paint fumes during the spraying phase. Therefore, they should always be kept clean; moreover, the good condition and efficiency of the pre-filters will help prolong the life of the filters inside the booth.

Access to the pre-filters is by the pre-filter inspection door and it is sufficient to extract them from their grooves. The wavy surface of the pads and containment mesh is designed to increase the area of the filtering surface and therefore it is recommended that original parts are used when it becomes necessary to replace them.

These filters should be cleaned initially with compressed air to remove the dust that has accumulated on both sides, and should then be washed with a high pressure water cleaner, taking care not to damage the material by using jets with too high a pressure. To avoid this, simply keep the cleaner hose at a distance of 70 / 80 cm. from the filter. The washing should be repeated several times on both sides for about 10 minutes per filter. Leave the filters to drip dry and then replace them in their grooves.

CLEANING FREQUENCY EVERY 100 HOURS

REPLACEMENT EVERY 6 MONTHS

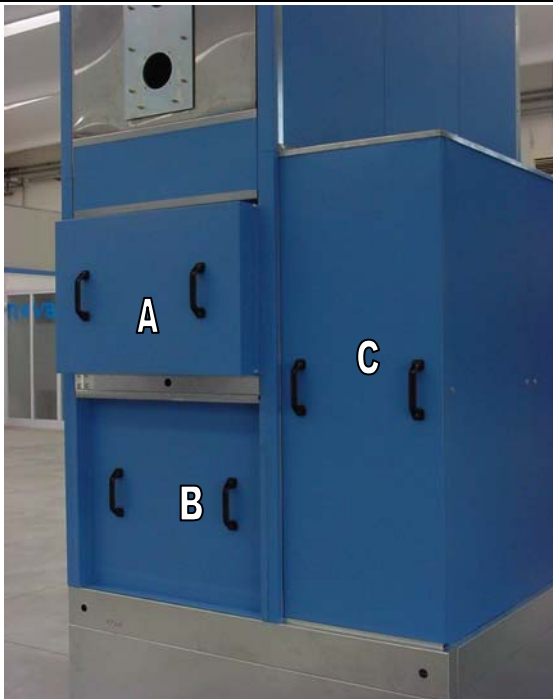

A: fan inspection door
B: prefilters inspection door
C: motor inspection door

MAINTENANCE PROGRAMME

PLENUM FILTERS

The plenum filters, more commonly known as ceiling filters, are inside the booth, at the top. They are inserted in white plastic-coated plate metal supports (filter holders), which are bent in such a way as to provide a structure capable of withstanding the force of the air, supported by hoops also made of pressed plate metal, and locked in place by filter holder stops that guarantee a hermetic seal.



Telai filtri
Finto filtro

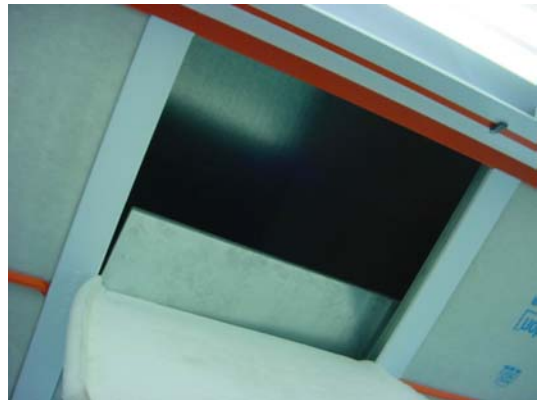

Reggetta



Controprofilo filtro

It is these filters that determine the result of the spraying. The progressive density filtering pad, which is capable of filtering particles up to 10 micron, guarantees the absence of dust in the air which is to surround the parts to be sprayed. Since they are subjected to sharp changes in pressure and temperature, it is important to check that no threads come loose from the lower part of the filter. With the booth in operation (spraying phase), compressed air should be blown over the whole of the filtering surface before the piece to be sprayed is introduced into the booth.

The filters can be replaced with the aid of a platform ladder, or preferably scaffolding if available, but without the need for any special equipment. The part of the filter which remains clean because no air passes through it, is the point of access to the filter dismantling system. It is sufficient to push upwards on that point to raise and remove the plate (false filter) that holds that part of the pad against the structure.

Simply remove the filter holder stops and take off the hoops to free the first pad and then proceed in the same way to dismantle all the others.

CLEAN EVERY 2 WEEKS	REPLACE EVERY 1000 HOURS
----------------------------	---------------------------------

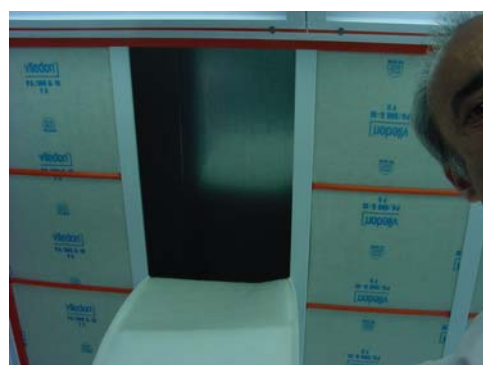
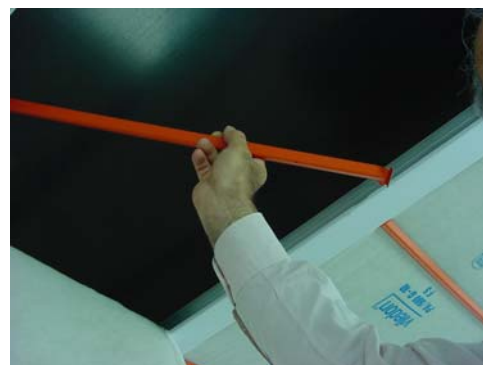

After dismantling all the filtering pads, clean all the filter holders and upper panels of the booth with a jet of compressed air and a cloth. During this operation it is advisable to switch on the booth for a few seconds so that the fans can remove all the dust from inside the booth.

To assemble the new filters, proceed in the reverse order:

After cleaning the hoops, position them on the reference notches, lay the pad between the filter holders and fix one end in place with the filter holder stop. Moving to the other end, fix it in the same way, taking care to stretch the filter thus fixing the other sides.

To close the last section, simply place the false filter over the frames and stretch it out under the end part of the pad.

Before using the equipment, clean all the new filters with a jet of compressed air in order to remove dust and other impurities that may have accumulated during their assembly.







UNDER GRATING FILTERS

These filters are located below the gratings, usually around the perimeter of the vehicle area or over the whole of the filter floor. They are supported by under-grating meshes and it is these filters that are hit first by the flow of air leaving the booth, which contains all the paint powder that is not deposited on the vehicle or painted parts. For this reason, when they become clogged the effect is immediate and causes an increase in pressure in the booth which in turn may cause turbulence in the air flow.

Replacing these filters is very quick and simple:

- 1)Lift the gratings that cover the filters and take out the paint-saturated filter.
- 2)Clean the meshes to remove paint and dust residues.
- 3)Lay out the new filtering pad (green or blue side up).
- 4)After removing any paint encrustation on the gratings, put them back in position, taking care not to switch their original position if they have different load-bearing capacities: place the heavy gratings on the rows which bear the weight of the vehicle.

MAINTENANCE FREQUENCY: EVERY 100 HOURS



WARNING !!
DISPOSE OF THE USED FILTERS AND
PAIN T RESIDUE AS SPECIAL WASTE

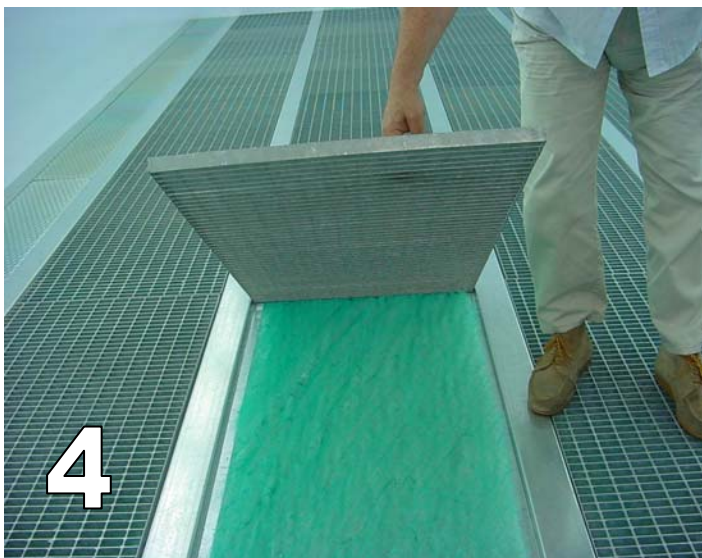

The extraction sets are designed to clean the air leaving the spray booth containing particles of paint which have escaped the paint stop filters located under the gratings.

Equipped with fans and motors designed to overcome the resistance of the filters to the passage of air, they enable the air pressure inside the booth to be balanced and to be kept at the minimum value necessary for the efficient operation of the equipment.

For their technical features, four types of air cleaning system are categorised:

1. **DRY FILTRATION** series EU1 EU1,5 EU2
2. **DRY FILTRATION WITH ACTIVATED CARBON** series EU1CA EU1,5 CA EU2CA
(the number following the letters CA indicates the number of cartridges containing the activated carbon)
3. **WATER WASH CLEANING** series WW (water wash)
4. **WATER WASH CLEANING WITH ACTIVATED CARBON** series WWCA



1) DRY EXHAUSTER



2) DRY EXHAUSTER WITH ACTIVE CHARCOAL



WARNING !!
DISPOSE OF THE USED FILTERS AND
PAINT RESIDUE AS SPECIAL WASTE

3) WATER WASH CLEANING SYSTEM

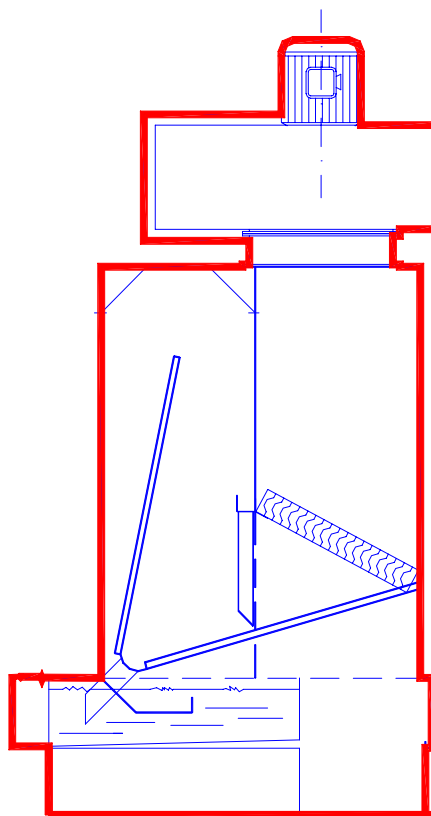

4) WATER WASH CLEANING SYSTEM WITH ACTIVATED CARBON

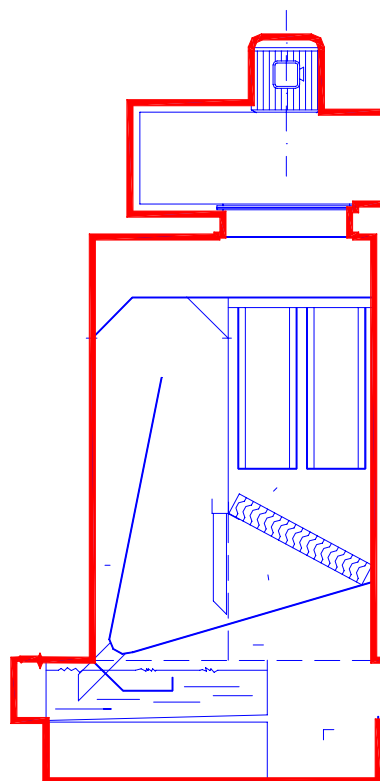

DRY EXTRACTION SETS EU 1 EU 1,5 EU 2

The inspection door provides access to the compartment containing the filtering cells, placed in the form of an upside down V to increase their surface area. These are supported on guides which allow them to be replaced quickly without the need for any tools. Air passes through the filtering pad from the bottom upwards and the pad's special synthetic fibre structure captures the paint particles carried in the air.

The accumulation of paint in the filter as the operating hours mount up obstructs the flow of air and thus causes an increase in air pressure inside the booth.

To keep the pressure within the optimal values, refer to the instructions provided later on in this manual under the heading "PRESSURE INSIDE BOOTH".

To replace the filters simply:

- 1) Open the inspection door.
- 2) Remove the frames containing the saturated pads from the racks.
- 3) Clean the internal walls of the set, check the state of the fans and remove any paint that may have collected on the blades.
- 4) Insert the cells containing the new pads into their guides.
- 5) Close the inspection door.

NOTE: Failure to replace the expulsion filters may lead to serious consequences for the extraction turbine. The paint contained in the air being expelled will reach the exhaust fan and stick to the blades because of the effect of centrifugal force, causing a loss of balance. The immediate effect of this will be strong vibrations in the set that may be transmitted to the whole equipment. These vibrations can, within a short time, cause the fan itself to break.

MAINTENANCE FREQUENCY: 150 OPERATING HOURS



DRY EXTRACTION SET WITH ACTIVATED CARBON EUCA

In addition to the extraction filters, the activated carbon filters contain the cylinders with the activated carbon.

The function of the activated carbon is exclusively to retain volatile organic compounds (VOCs) mixed with air, such as solvent vapours, additives and other chemical components contained in the sprayed products.

Dust and paint residues, on the other hand, are retained by the extraction filters placed before the activated carbon and by the filtering socks inside the cartridges.

The cartridges consist of two concentric cylinders of wire mesh between which is the activated carbon, compressed into small cylinders of 3-4 mm diameter. The two meshes are held in place at the top by a closed cap and at the bottom by a ring which also serves to centre the cartridge on the holes in the support base. It also has the function of keeping the filtering sock in place inside the cartridge.

The air blown out by the ventilator comes into contact with the extraction filters followed by the filtering sock and then, by this time cleaned of any paint or dust residues, passes through the activated carbon for the width of the cartridge.

DIAGRAM OF THE DRY FILTRATION SYSTEM WITH ACTIVATED CARBON

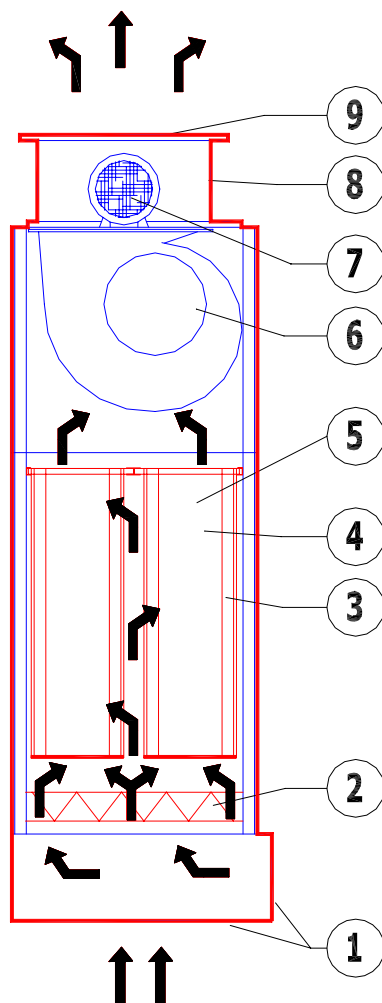

LEGEND

- 1) air intake into dry filter
- 2) extraction filter cells
- 3) wire mesh cylinders
- 4) filtering sock
- 5) activated carbon
- 6) extraction fan
- 7) motor
- 8) regulation damper
- 9) air exit outlet

EFFICIENCY AND DURATION OF ACTIVATED CARBON CARTRIDGES

The duration of the efficiency of the activated carbon depends mainly on the quantity of volatile products that into contact with it and on the speed of passage, that is, the time of contact between the substances to be absorbed and the cylinders of carbon.

It is estimated that the activated carbons can retain a quantity of organic volatile compounds (VOCs) of between 16 % and 18 % of their own weight. Taking into consideration also the normal degree of dilution of paints, an approximate estimate may be made that 1 Kg. of activated carbon should be able to clean air containing 1 Kg. of sprayed product.

REPLACEMENT OF EXTRACTION FILTERS, FILTERING SOCKS AND ACTIVATED CARBON

EXTRACTION FILTERS: EVERY 150 OPERATING HOURS

- 1 Disconnect the power supply from the control panel to prevent accidental starting up of the fans
- 2 Open the filtration system inspection door
- 3 Remove the filters situated horizontally beneath the activated carbon cylinders from their guides
- 4 Replace with original new filters

FILTERING SOCKS: EVERY 500 OPERATING HOURS

- 5 Take out the first row of cylinders, remove the cylinder holding panel and then take out the second row and so on to the last row.
- 6 Holding the cartridges with the ring upward, take the ring off by undoing the fixing screws.
- 7 Remove the filtering sock to be replaced from each cartridge.
- 8 Insert the new filtering sock into the cartridge
- 9 Fasten the socks with the rings and secure the rings to the meshes with the screws.
- 10 Put the cartridges back into position over the holes of the cylinder holding panels with the rings at the bottom and push them inside the filtration system.

ACTIVATED CARBON: DEPENDING ON THE QUANTITY OF SPRAYED PRODUCT

Perform steps 5 to 7 above, then:

- 11 Empty the activated carbon into a container
- 12 Clean the dust and paint off the mesh cylinders
- 13 Fill the cylinders with new carbon, taking care to keep the meshes in perfectly concentric position.
Perform steps 8 to 10 above
- 14 Close the dry filter inspection door.



ACTIVE CHARCOAL CARTRIDGE



**WARNING !!
DISPOSE OF THE USED FILTERS
AND PAINT RESIDUE AS SPECIAL WASTE**

CENTRIFUGAL FANS

The centrifugal fans are installed both in the heat ventilator sets (generators) and in the filtration sets (air cleaning system). The fans mounted on the air filtration sets require greater maintenance care since they carry out the extraction of air contaminated with paint particles from the booth which can create serious problems as indicated earlier.



WARNING !!!
BEFORE OPERATING ON FREE-MOVING PARTS,
EVEN AFTER ISCONNECTING THE POWER
SUPPLY, WAIT FOR THE ROTATION TO COME
TO A COMPLETE HALT.

GREASING OF BEARINGS

1.) Turn the master switch to "OFF "
2.) Open the inspection door
3.) Using an appropriate lubricator, grease the bearings on both sides of the fan
4.) Check the tightness of the nuts fixing the fan to the shaft and of the bearings locks.
5.) Close the inspection door
6.) Reconnect the power supply.

FREQUENCY: EVERY 500 OPERATING HOURS

DISMANTLING FOR CLEANING OR REPLACEMENT

Repeat steps 1 e 2 above

- 3) Loosen and remove the transmission belts by unscrewing the fixing screws of the motor or operating the control levers on the oscillating plate.
- 4) Remove the screws attaching the fan to the frame
- 5) Remove the fan by sliding it along the rails
- 6) Mount the new or cleaned fan repeating the same steps in reverse order.

CLEANING THE WHEEL

Dopo aver estratto il ventilatore dal suo alloggiamento, seguendo le indicazioni sopra riportate, occorre rimuovere da ogni singola aletta lo strato di vernice formatosi nella parte concava delle stesse.
 N.B. E' necessario aver cura di non alterare la geometria delle lame per non compromettere il bilanciamento.



WARNING !!
DISPOSE OF THE USED FILTERS AND
PAINT RESIDUE AS SPECIAL WASTE

SLIDING THE WHEEL ONTO ITS SHAFT

It is likely that after a period of time, the screws fixing both the fan wheel and the bearings to its shaft will begin to loosen. This may cause movement in all the rotating parts with the consequent collision of the wheel with the fixed part of the fan, causing an unpleasant noise.

It is essential that the correct position is re-established before irreparable damage is caused to the fan. To do this, proceed as follows:

1. Check whether the movement involves the whole shaft in the two bearings or only the wheel on the transmission shaft.
2. Loosen the fixing nuts that are still tight to facilitate restoration of the correct position.
3. Tap lightly with a hammer, placing a piece of wood in between the part to be moved and the hammer to avoid damaging the parts, until the original position is reached
4. Check that the distance between the wheel and the fixed part of the fan are completely equal on both sides.
5. Tighten the screws fixing the wheel and the bearings to the transmission shaft.



TRANSMISSION SHAFT
BEARING AND WHEEL

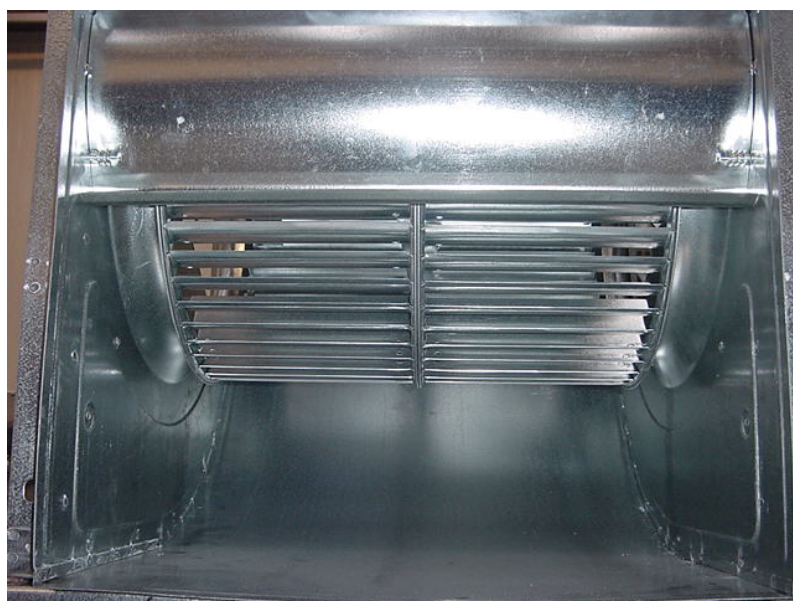

WHEEL IN CENTRAL POSITION
ON FIXED PART

WATER WASH EXTRACTION SETS SERIES WW WWCA

The water wash cleaning system carries out blast-cleaning of the paint contained in the air extracted from the booth using the principle of the "venturi" system illustrated below.

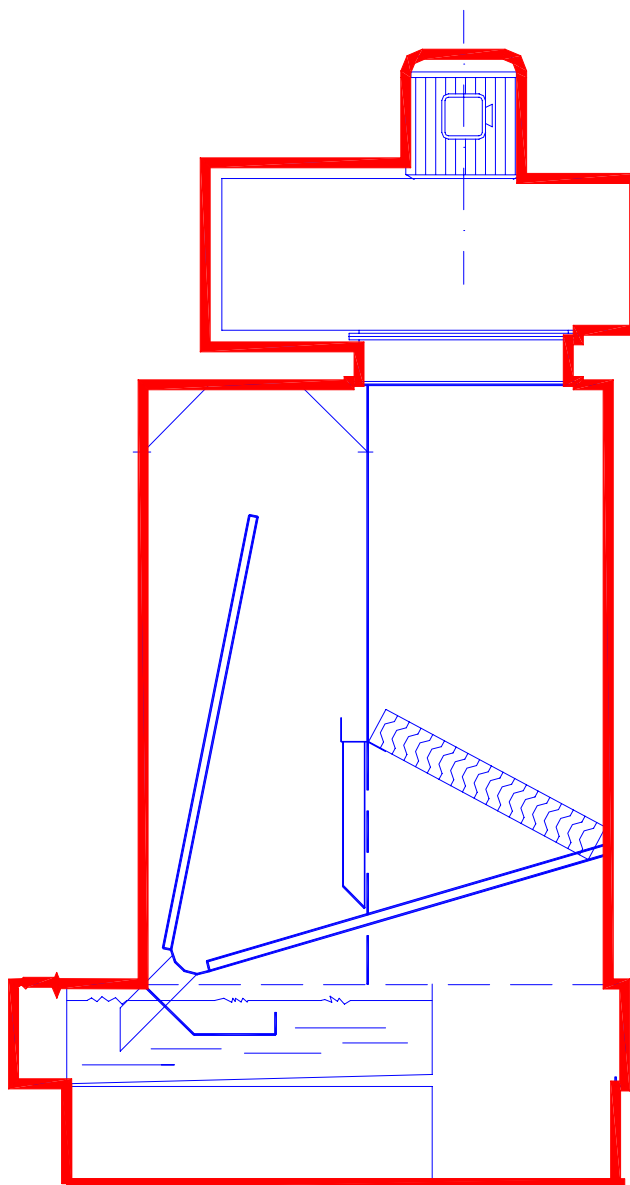

To keep the WW series cleaning system in perfect working order, it is sufficient to carry out certain checks and perform some simple but vitally important operations.

- 17) EVERY MORNING WHILE THE CLEANING SYSTEM IS STILL SWITCHED OFF, use a net to skim off the layer of paint that has formed on the surface of the water in the two side collection tanks.
- 18) Check that the level of the water in the supply tank is 25 / 30 mm below the rim of the tank
(about halfway up the nut that holds the ball float in the tank)
- 19) Check that when the ball float is pushed down manually, the water flows down the pipe
(any taps or gate valves on the pipes can remain closed)

ATTENTION

The water level also serves to regulate the pressure inside the booth (see paragraph "INTERNAL PRESSURE REGULATION" in this manual).



- 4) Disconnect the power supply from the control panel to ensure that the filtration system is not started accidentally.
- 5) Open the inspection door of the set, remove the water trap filters from their holders and check their condition. If they are encrusted with paint they should be cleaned or replaced.
- 6) Check the internal walls of the filtration system and remove any paint residue from them

- 7) Clean the fan blades thoroughly
- 8) Empty out the water in the tank and remove the muddy sediment left on the bottom.
- 9) Refill the tank with clean water up to the level (point 2)
- 10) Put the water trap filters back in place after having removed all paint encrustations, taking care to place them with the arrow pointing upwards.
- 11) Close the inspection door and reconnect the power supply.

MAINTENANCE FREQUENCY: 300 OPERATING HOURS

WW CA

REPLACE THE ACTIVATED CARBON ACCORDING TO THE AMOUNT OF SPRAYED PRODUCT USED, PROCEEDING AS FOLLOWS

1.) Disconnect the power supply from the control panel to ensure that the fan is not started accidentally.
2. Open the inspection door of the set.
3. Take out the water trap filters so as to be able to access the inside of the set
4. Slide the cartridges containing the activated carbon out of the holding guides
5. Remove the lower cap, unscrewing the stop nut
6. Empty the carbon out of the two mesh cylinders
7. Clean the paint residue off the cylinders
8. Refill with new carbon, trying to compact it as much as possible
9. Replace the bottom cap and fix it with the stop nut
10. Insert the containers into the set
11. Replace the drop separator cases in the correct position (arrow pointing up)
12. Close the inspection door
13. Reconnect the power supply

DIAGRAM OF WATER WASH CLEANING SYSTEM
WW CA SERIES

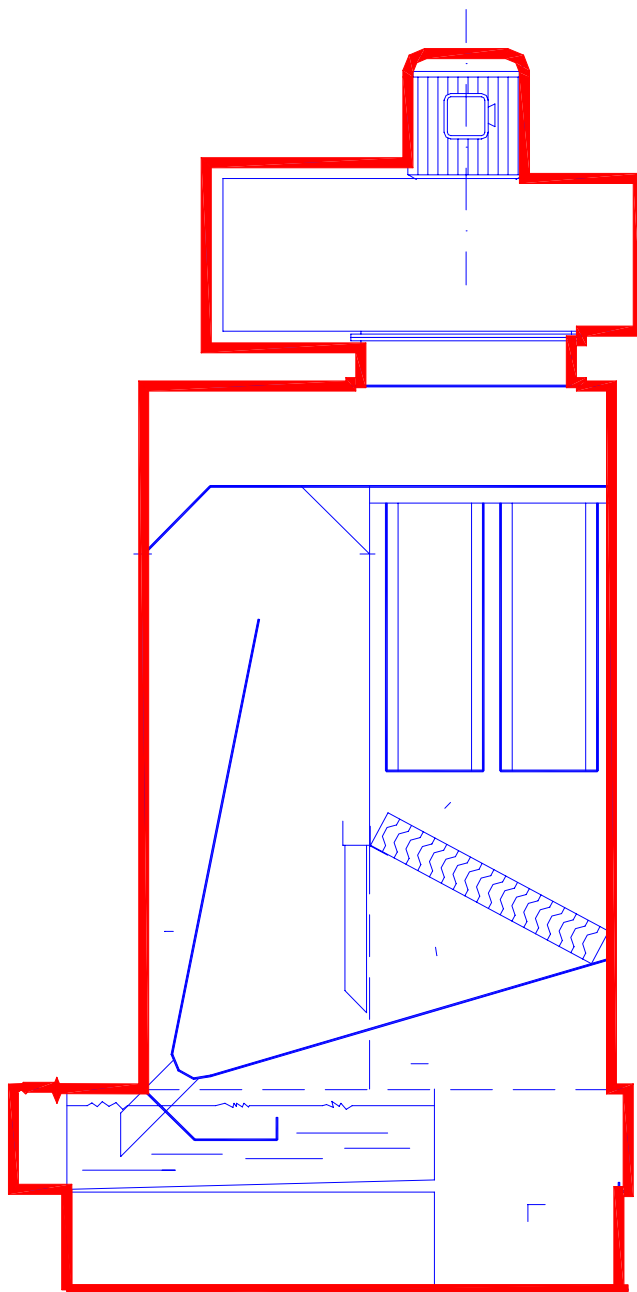

PRESSURE INSIDE BOOTH



N.B. THE PRESSURE MUST BE CHECKED WITH THE BOOTH IN "SPRAY" MODE"

The level of pressure inside the spray booth is a continually rising parameter due to the daily clogging of the filters, both at the air intake and the air outlet. It is necessary to reset the correct pressure daily and always after replacement of any type of filter or after carrying out any operation that may cause a variation in the air flow.

The appropriate pressure level is significantly different between a booth operating with balanced air, that is with an extraction set, and a booth operating on free exhaust, that is with expulsion of the air by the intake fans.

In the latter case, the internal pressure is determined by the air flow from the intake fans and by the resistance provided by the exhaust ducting. The maximum value corresponds to 4 mm of water column.

BOOTH WITH EXTRACTION SET

In this case the pressure must be maintained between the values 0 and 2 mm of water column. The pressure should be checked with the vehicle to be sprayed inside the booth, in the centre, and with the equipment operating in spray phase.

Pressure regulation should be carried out as follows, depending on the configuration of your equipment:

EQUIPMENT WITHOUT MANOMETER AND MANUAL CONTROL DAMPER

The regulation must be carried out in a qualitative manner depending on the air thrust revealed on the service door in the following way.

Cut out a strip of paper about a centimetre wide and 15 / 20 cm long and hold it in front of the service door which should be only a few millimetres open as indicated below.

The air flow that is created in a spiral will push the strip of paper inwards if the pressure is negative and outwards if the pressure is positive. The pressure should be regulated so that the strip of paper remains in a vertical position with slight oscillations outwards. This can be achieved by operating the control damper on the extraction ducting. To do this it is necessary to undo the stop knob and move the control lever a few millimetres (towards OPEN to reduce the pressure and vice versa to increase it). Tighten the stop knob again when the regulation has been completed.



MANUAL CONTROL DAMPER

THE FLOW OF AIR MOVES THE STRIP OF PAPER INWARDS.

THE PRESSURE VALUE IS NEGATIVE.
SLIGHTLY CLOSE THE DAMPER



THE FLOW OF AIR MOVES THE STRIP OF PAPER OUTWARDS WITH FORCE.

THE PRESSURE VALUE IS TOO HIGH.
OPEN THE DAMPER.



THE STRIP OF PAPER SWINGS
SLIGHTLY OUTWARDS

CORRECT SETTING FOR EXTRACTION
DAMPER

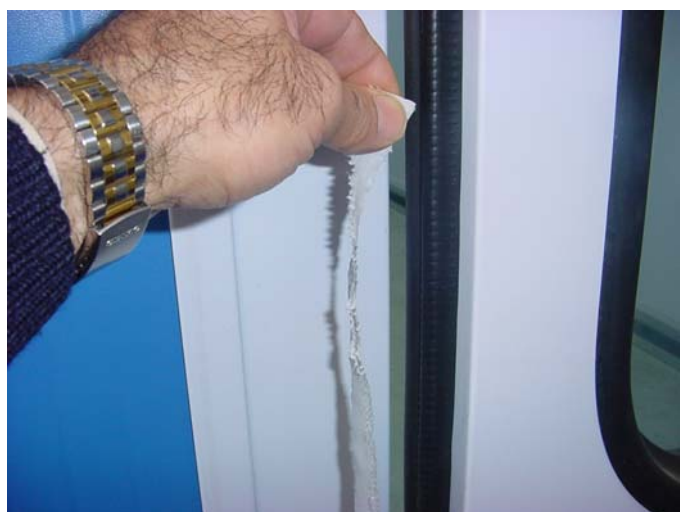

SETTING UP THE DWYER MANOMETER FOR PRESSURE REGULATION

Mount the instrument in a vertical position (on the wall of the booth), using the two attachment screws through the two holes in the panel, positioning it perfectly level with the use of the level system provided on the instrument itself.

Next turn the knob marked "ZERO SET" as far as it will go, turning it anticlockwise until it stops. Make a mark with a pencil at 12 o'clock on the knob, then turn it clockwise counting the number of turns until it stops (about 8 turns). Turn it anticlockwise again for half the number of turns made previously.

Now connect the HIGH pressure tapping point located on the upper part of the instrument to the inside of the booth with the duct provided, making a hole through the wall.

Check that the duct is not squashed by bending it too sharply and that the heat insulation material in the wall does not obstruct the duct. The LOW pressure tapping point should be left free.

Unscrew the FILL cap and gradually pour in the red liquid from the bottle until it appears on the graduated scale. Wait a few minutes for the liquid to move down the container, then close the FILL cap. Position the green and red self-adhesive arrows to correspond to the values 0 and 0.2 respectively on the graduated scale.

REGULATION OF THE ZERO

- 1 . The booth should not be in operation.
- 2 . Open the service door of the booth.
- 3 . Turn the knob ZERO SET clockwise if the red liquid has settled at a value below 0, and anticlockwise if the liquid has settled above 0 .

WARNING: Do not carry out ZERO regulation if there is suction equipment in operation in the area. The value will be falsified through the depression effect.

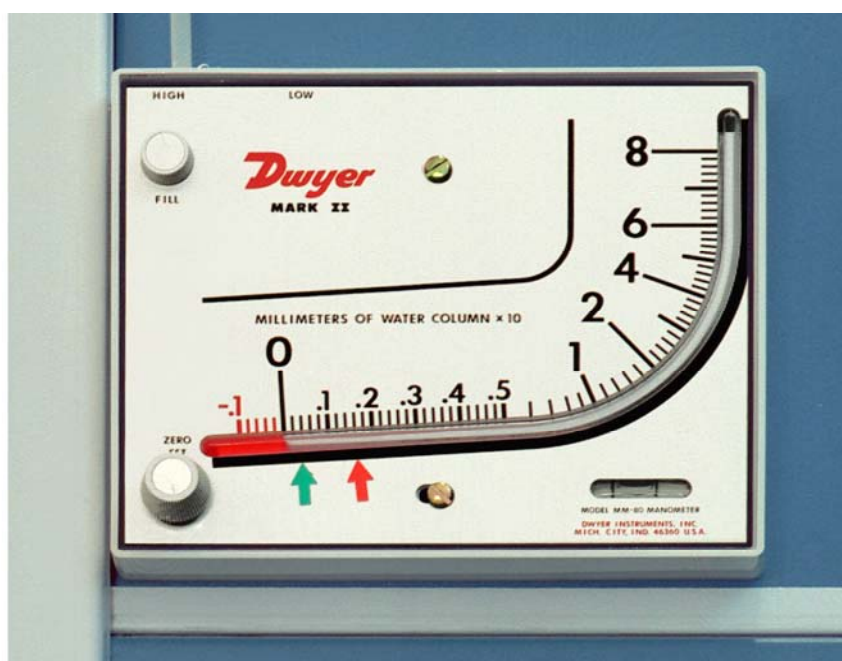

2. Equipment with manometer and manual control damper

In this case the pressure is checked by observing the value indicated by the red liquid on the instrument's graduated scale. The booth should be in operation (spray phase).
To operate the extraction damper, undo the knob that blocks the control lever. Open and close the damper to bring the liquid to the value at the green arrow.

3. Equipment with manometer and automatic control damper operated from control panel

As in the preceding paragraph, the pressure is indicated by the instrument.
Regulation is carried out from the control panel by turning the open/close potentiometer very slightly, waiting between each turn to allow time for the damper motor to move to the new position, thus altering the pressure.



MOTORISED CONTROL DAMPER



CONTROL POTENTIOMETER

4. Equipment with automatic control

In booths equipped with a control panel and electronic control apparatus, the pressure in the booth is preset and is kept constant completely automatically.

5. Equipment with water wash extraction set without control damper

In booths equipped with a water wash cleaning system, the water level in the tank itself determines the pressure inside the booth.

Start up the equipment in spray position. Check whether the pressure is anomalous, and if it is, as indicated by the manometer or by the thrust of air on the door, it is necessary to drain off some water from the tank if the pressure is too high or to add water if the pressure is too low. When the optimal pressure is reached, the ball float rod should be adjusted in such a way as to make water flow into the tank when the level goes below this point.



BEND THE BALL FLOAT ROD TO SET THE NEW OPENING POINT

MAINTENANCE PROGRAMME
TRANSMISSION BELTS

The "belt-pulley" transmission system generally used in NOVA VERTA's ventilating sets allows the number of fan rotations to be adapted to specific requirements by altering the motor-ventilator pulley ratio.

Periodic control is necessary to check the correct tension of the belts and their elasticity to prevent slipping of the belts in the pulleys. This would cause a reduction in the performance of the fans, accelerated wear and tear of the belts and an unpleasant noise when the fans start up.



WARNING !!!!
BEFORE SERVICING THE TRANSMISSION BELTS,
DISCONNECT THE POWER SUPPLY TO THE
CONTROL PANEL IN ORDER TO PREVENT
ACCIDENTAL START UP OF THE EQUIPMENT.



The correct tension can be verified by applying manual pressure to the belts at a point about halfway between the two pulleys as indicated in the photo. The overall bending should not exceed 20 / 30 mm.

Check that there is no loss of alignment between the pulleys. If there is, reset the alignment.



TENSION CHECK

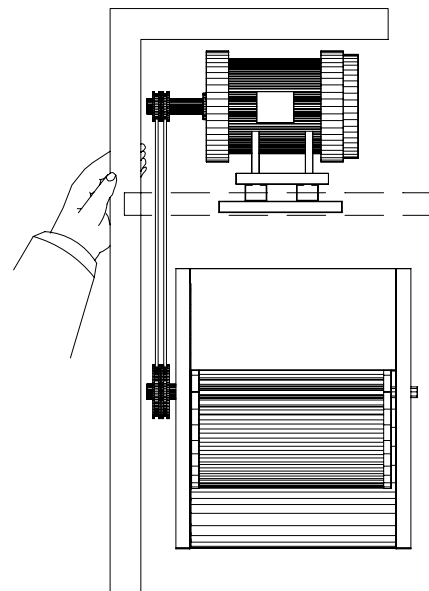

ALIGNMENT CHECK

Regulation of the belt tension differs according to the construction characteristics

1. If the motor is mounted on horizontal slides:

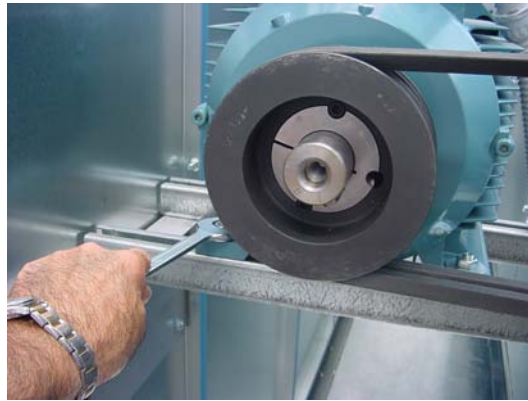
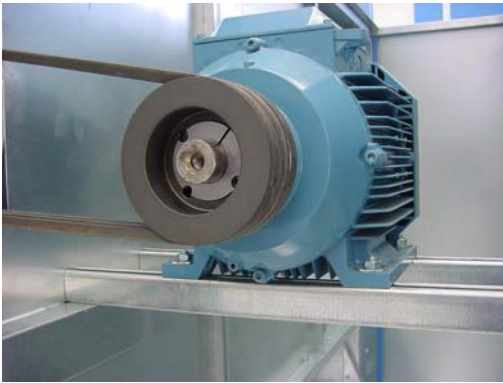

Loosen the four fixing screws, slide the motor along the guides so as to increase the distance between the pulleys and stop it at the point where the correct belt tension is reached. During this operation it is necessary to maintain perfect alignment of the pulleys, and when tightening the fixing screws check that the small hammer on the inside of the guides is in a crosswise position to the guides.

2. If the motor is mounted on vertical slides:



Loosen the four screws fixing the motor to the slides, allow it to slide down by the effect of gravity and stop it again at the point where the correct belt tension is reached.

During this operation it is necessary to maintain perfect alignment of the pulleys, and when tightening the fastening screws check that the small hammer on the inside of the guides is in a crosswise position to the guides.

3. The motor is fixed to a tilting plate:

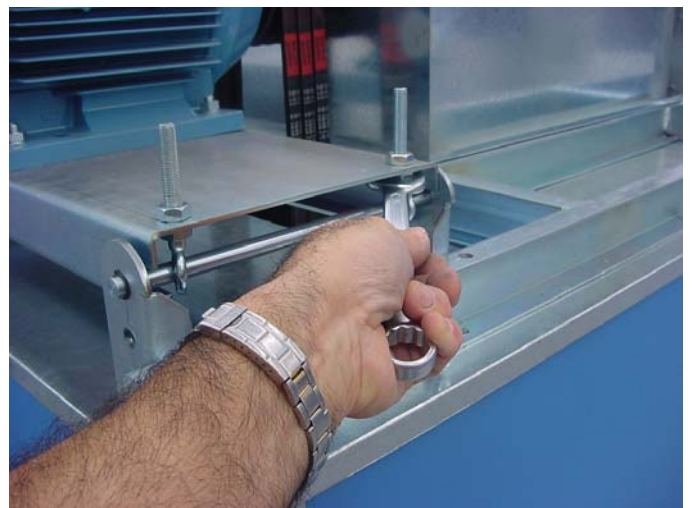
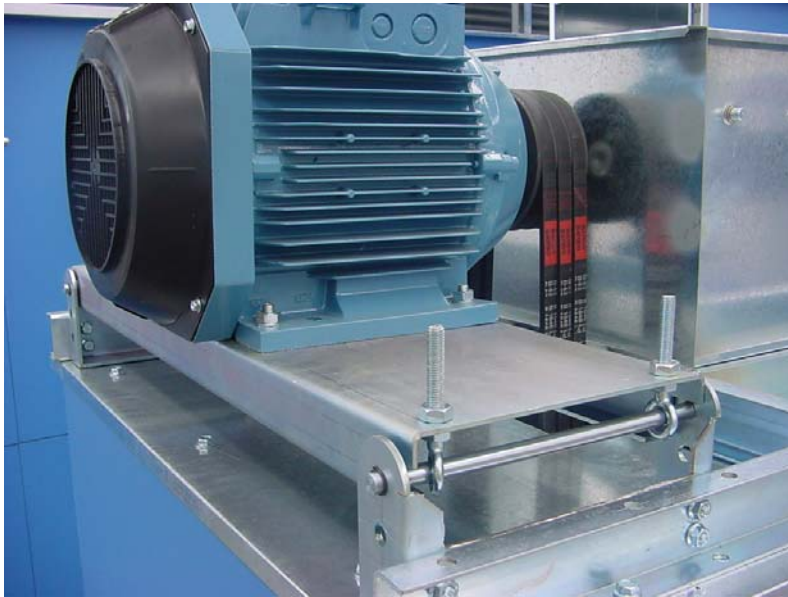

Use the control rods to tilt the plate upwards so as to increase the distance between the pulleys. Tighten the nut and lock nut again to fix the tilting plate.

**TENSION CHECK: EVERY 500
OPERATING HOURS**

**REPLACEMENT OF BELTS: EVERY 1500
OPERATING HOURS**

ELECTROVALVES AND PNEUMATIC PISTONS

The electrovalves operate the recirculation doors or BY PASS dampers for the whole operating cycle of the booth. Two versions are provided

MODEL 22	CONTROL OF RECIRCULATION DAMPER PISTONS
MODEL 42	CONTROL OF RECIRCULATION DAMPER PISTONS AND OF COMPRESSED AIR FROM SPRAYING GUN IN BOOTH

They are housed inside a protection case and are generally installed near to the hot air generator set.



ELLO 22



MODELLO 42

TO CHECK THEY ARE FUNCTIONING CORRECTLY

When parts are replaced in the electrovalves, pneumatic pistons, ducting or when other maintenance operations are carried out on the pneumatic equipment for the recirculation door, it is necessary to check that the system is functioning properly.

- Ensure that the master switch on the control panel is at (0)
- Set the pressure on the electrovalve manometer (if provided) to about 6,5 bar.

In this condition the recirculation door should be closed (spray position). If, on the other hand, the door is pushed upwards by the piston (baking position), the air ducts on the piston must be exchanged..



BYPASS DAMPER CLOSED
(SPRAYING PHASE)



BYPASS DAMPER OPEN
(BAKING OR RECIRCULATION PHASE)

REGULATION OF SPEED OF OPENING/CLOSING OF VALVES

The speed with which the dampers change from one position to the other can be regulated in order to prevent them from slamming. The change should take about 5 seconds and to achieve this timing there are some adjustment screws.

Proceed as follows:

- Ensure that the control panel is at (0)
- Regulate the pressure on the manometer to about 6,5 – 7 bar
- Press the two manual activation screws simultaneously, the piston pushes the damper upwards as far as it will go
- When the pressure on the screws is released, the dampers lower again to the original position
- Check the speed of the opening and closing of the doors
- Repeat the same operation several times, each time using the adjustment screws to obtain the optimal speed.
- Fix the lock nuts on the adjustment screws so that the positions do not change
- Test again after having tightened the lock nuts.

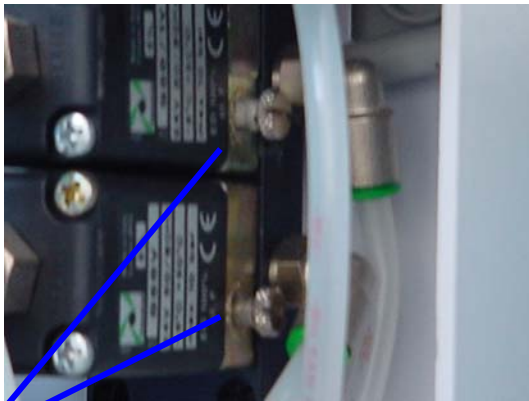

MANUAL ACTIVATION SCREWS

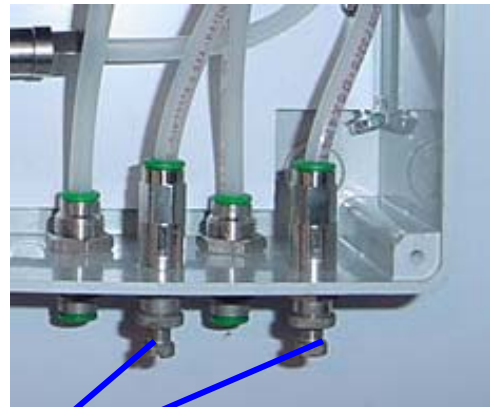

ADJUSTMENT SCREWS

CHECK CORRECT FUNCTIONING EVERY 100 OPERATING HOURS

INTAKE DAMPER WITH COUNTERWEIGHT

In the generator sets series LMU 1 , LMU 1,5 and LMU 2, the main function of the recirculation dampers is to open up the passage of air so that it can be recirculated during the heating phase but at the same time, when they are raised, they close the intake of cold air from the outside during the baking phase, only allowing 10 – 15% of it to enter in order to prevent solvent saturation in the booth.

In the generator sets SMU 1, SMU 1,5 and SMU2 the intake damper performs this function, activated by a counterweight that keeps it closed when the equipment is off and during the baking phase, while the pressure on the fins of the air sucked in from the outside by the ventilators causes the counterweight to rise and thus the damper to open.



DAMPER CLOSED



DAMPER OPEN

To check that the damper with counterweight is functioning properly, proceed as follows :

1. Turn the master switch on the control panel to (0)
2. Lift the counterweight manually, causing the damper fins to open until they are horizontal and the rod stops at the adjustment screws.
3. Release the counterweight and check that it goes down with the effect of gravity, causing the fins to close.

If the damper remains open, carry out the following actions until normal functioning returns:

4. Grease the bushings on which the pins of the fins turn and repeat steps 2 and 3.
5. Reduce the friction by slightly loosening the bolts connecting the rods and repeat steps 2 e 3.

When the damper is functioning correctly, it is necessary to check that this also occurs during normal operating conditions, that is with the equipment in operation, when the flash-off phase ends and the baking phase begins.



SETTING SCREW TO KEEP THE ABSORPTION OF THE INTAKE MOTORS WITHIN THE NOMINAL VALUE



CHECKING FREQUENCY EVERY 100 OPERATING HOURS

SEALS

E' It is quite normal that, with the passing of time and with the high temperatures to which they are subjected, the seals on the booth doors and on the recirculation dampers lose their elasticity and no longer provide a perfect seal.

Consequently, if they are not replaced with time, in booths operating even with light positive pressure, there is leakage of air containing paint pigments to the outside and paint encrustations form along the edges of the doors, resulting in an unpleasant appearance.

Replacement is simple and quick since the seals are mounted on grooves.

To order a seal kit from NOVA VERTA, simply indicate the number of panels in the booth front door and the height of the door.



POSITION OF THE SEALS ON THE RECIRCULATION DAMPERS

SIDE WALLS

The side walls of the booth must always be kept clean and dust-free to obtain maximum brightness.

It is likely that they will come into contact with the paint powder from the pistol if this is directed towards them at close range and therefore it is advisable to protect them with transparent plastic sheeting from the first time of operation.



LIGHTING

The booth is provided with a light fitting with neon fluorescent tubes in two rows in the ceiling and in some models also on the side walls.

These are protected by glass mounted on metal housing hinged to the containment box with an inward-facing hermetic seal. They should be kept permanently clean in order to obtain maximum lighting performance and optimal working conditions.

N.B BEFORE REPLACING PARTS ON THE LIGHTING FIXTURE PANEL, ENSURE THAT THE MASTER SWITCH ON THE CONTROL PANEL IS AT (0)

To access the inside of the lighting fixture panel, unscrew the locks and open the housing on its hinges.

MAINTENANCE PROGRAMME DUCTING --- HEATER --- BURNER

INTAKE DUCTING

The intake ducts with bird-proof netting at the end may become blocked by debris carried by the wind such as leaves, plastic bags etc. that adhere to the duct opening. This causes a reduction in the duct area with a consequent decrease in the amount of air.

It is important to check that the protection netting always remains clear

EXHAUST DUCTING

The air exhaust ducting may become obstructed through the accumulation of paint powder which is not retained by the filters, especially ducts with rain protection bends and protection netting. It is essential that the ducts are always kept clean.

MAINTENANCE FREQUENCY : 1000 OPERATING HOURS

HEAT EXCHANGER

Check that the heat diffusion fins inside the heat exchanger are in the correct position, that is, in line with the radiators.

N.B. When assembling the equipment, your regular plumber should drain off the condensation both from the heater and from the vent ducting.

The maintenance and cleaning of the heater must be carried out by specialised personnel.

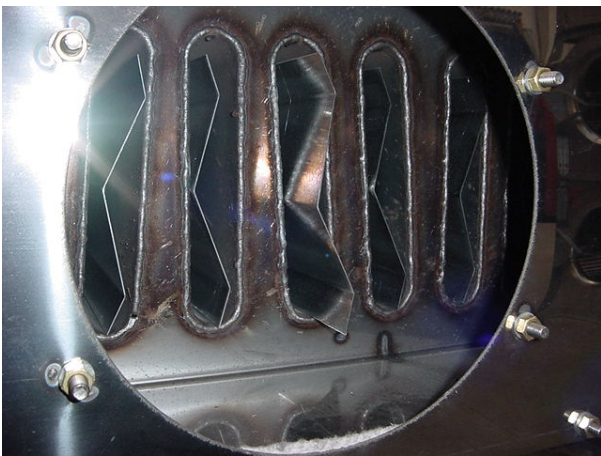

DIFFUSION FINS

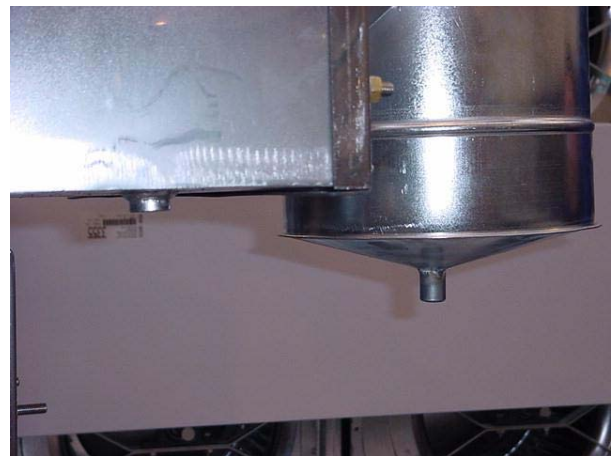

CONDENSATION DRAINS

BURNER

Maintenance and any necessary repairs must be carried out by professional, specialised personnel.

Consult the burner manufacturer for information on the nearest service assistance centres. The local service engineer should carry out the inspection, regulation and cleaning of the burner.

Should the burner be tampered with by any personnel who are not authorised by the manufacturer, the burner guarantee will no longer be valid.

